

M-Diff BMW X-Drive 175

DSD-100-100-5001658

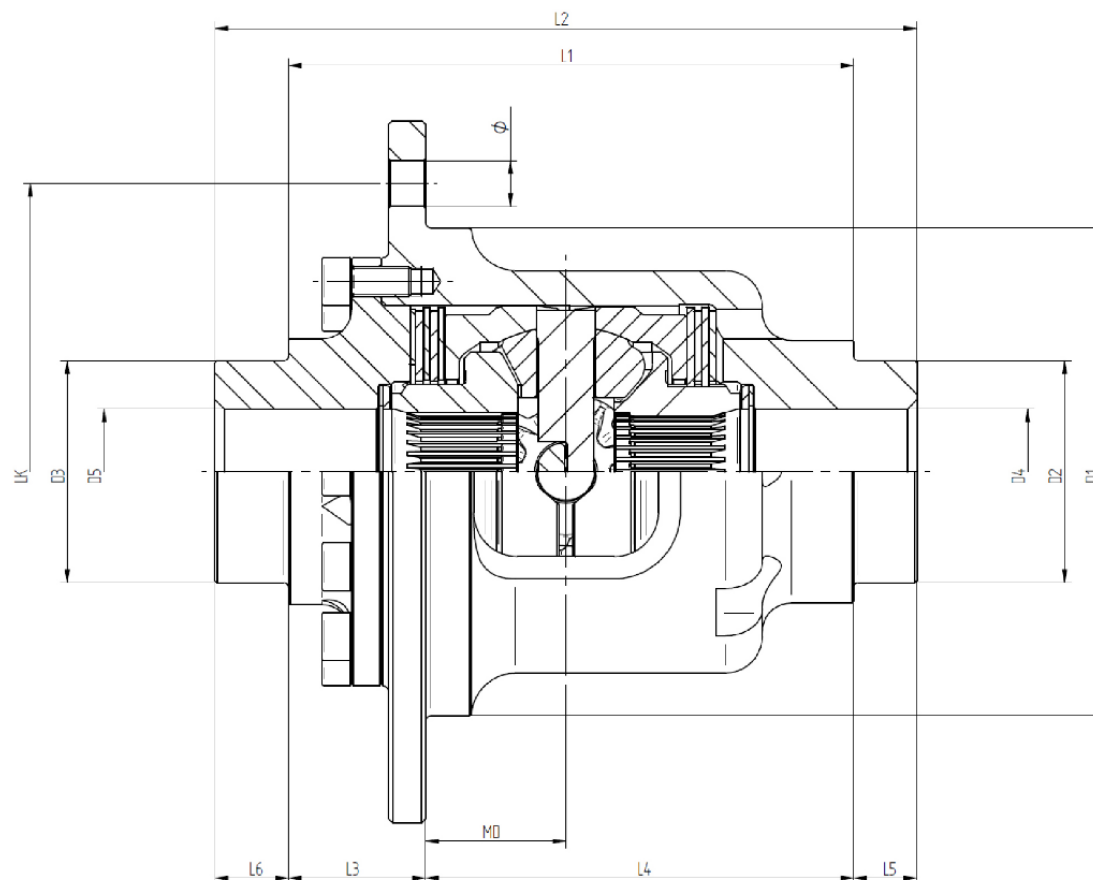

	DREXLER	KUNDE CUSTOMER
	Fahrzeughersteller Vehicle manufacturer	BMW
	Fahrzeugmodellserie Vehicle series	X-Drive
D1	Tellerrad Durchmesser Crown Wheel Spigot DIA	101,00
D2	Lagerdurchmesser Gehäuseseite Bearing DIA Housing Side	41,30
D3	Lagerdurchmesser Deckelseite Bearing DIA Cover Side	41,30
D4	Bohrung Gehäuseseite Bore DIA Housing Side	30,00
D5	Bohrung Deckelseite Bore DIA Cover Side	30,00
L1	Lagerweite Bearing Distance	89,50
L2	Gesamtlänge Overall Length	132,50
L3	Länge Lager/Tellerrad Distance Bearing/Crown Wheel	56,80
L4	Länge Tellerrad/Lager Distance Crown Wheel/Bearing	32,70
L5	Länge Lager Gehäuseseite Distance Bearing Housing Side	21,50
L6	Länge Lager Deckelseite Distance Bearing Cover Side	21,50
MD	Abstand MD Distance MD	12,00
	Zähnezahl Number of Teeth	27
	Getriebetyp Transmission type	175



Letzte Aktualisierung: 06.02.2026